

## **Euro NCAP - New Frontal Impact Test with Mobile Progressive Deformable Barrier (MPDB)**

**Volker Sandner**

ADAC e.V.  
Germany

**Michiel van Ratingen, James Ellway**

Euro NCAP  
Belgium

On behalf of the Euro NCAP Frontal Impact Working Group

Paper Number 19-0196

### **ABSTRACT**

In 2015 Euro NCAP announced that the current offset deformable barrier frontal impact test procedure would be revised and a frontal impact working group was set-up to develop the new procedure. The aim was to bring together individual research efforts by FIMCAR [1], ADAC and other organisations [2,3] on the development of a ‘moving barrier to vehicle’ frontal impact test and derive common specifications for the new Euro NCAP test and assessment procedure from this. In partnership with the European Enhanced Vehicle safety Committee (EEVC), Euro NCAP examined the extent to which the advanced frontal THOR-M ATD is ready and suitable for use in this new test procedure. The overall results of the accident analyses, the specification of the test setup and the definition of the barrier were reported at the ESV 2017 in Detroit [4]. In the subsequent stage, the group focussed on the assessment criteria for the THOR dummy, the compatibility assessment and the full-scale evaluation of the procedure. Several round robin tests were organised to check the feasibility and repeatability of the method, in particular with regards to the THOR dummy and the barrier scanning. The group has released the final test and assessment protocols in 2018 for adoption in 2020, but will continue to monitor relevant developments, in particular related to dummy hardware and certification updates.

### **BACKGROUND**

In the first phase of work of the group, the basic foundations for the definition of the new frontal mobile barrier test were laid, especially test parameters like impact speed overlap, mass of the barrier, the definition of the mobile barrier face and the dummy positioning in the test vehicle. The new test is aiming at improving the biomechanical assessment of critical body region risk at injury and at assessing, for the first time, vehicle compatibility. As NHTSA has postponed the introduction of the new US NCAP that was announced in 2016, Euro NCAP will most likely be among the first world-wide to use the advanced THOR-M dummy as part of their assessment of vehicle’s crashworthiness. Several relevant documents pertaining the specification and certification of the latest dummy hardware remain unreleased by NHTSA until this date, which meant that the working group had to verify the latest built-level dummy’s repeatability and reproducibility and make some practical decisions regarding certification. Beside the dummy specification, injury criteria and the upper and lower reference values (limits) for the rating needed to be set. The biggest challenge, however, was to agree on the method by which vehicle compatibility could be assessed and included in the safety rating. Finally, the complete test procedure by R&R testing needed to be validated, so several test series were carried out in the Euro NCAP accredited laboratories to verify the test setup and assessment and to proof the test’s reproducibility in different labs with the same result.

### **TEST SPECIFICATION**

The actual car-to-barrier test specification was agreed in 2016 with both the vehicle and the barrier approaching at 50kph (MPDB). The test vehicle is equipped with a THOR 50<sup>th</sup> percentile male dummy (THOR 50M) on the driver seat and a Hybrid III 50<sup>th</sup> percentile male dummy (H-III 50M) on the front passenger seat. In the second row, a Q10 dummy is placed on the struck side while the Q6 dummy is seated on the non-struck side, the results of which are used for the Child Occupant Protection assessment in Euro NCAP. The overlap is moderate at 50 percent of the total vehicle width. The moving trolley carries a progressive deformable barrier [5,6] on the front outboard side and has a mass of 1400kg (Figure 1).

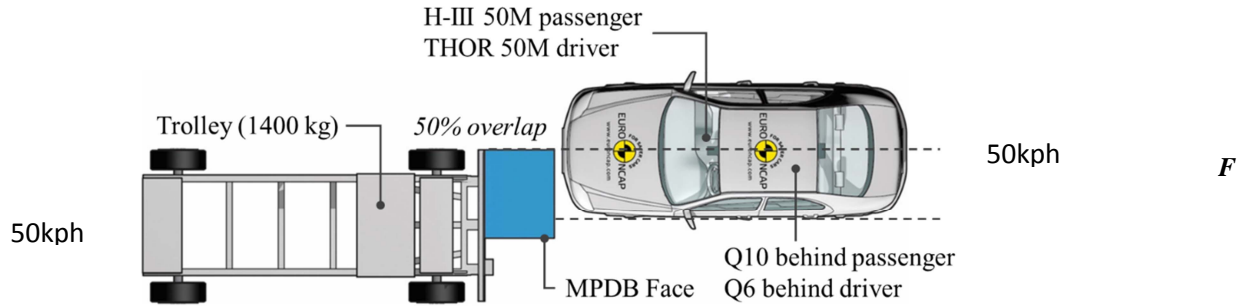

figure 1: Impact condition of the MPDB test

## ASSESSMENT CRITERIA

Euro NCAP has carried out the frontal offset deformable barrier (ODB) testing for more than 20 years. During this time, there have only been minor changes to the assessment of the vehicle performance. From the beginning, the test score was based on actual dummy scores (based on injury limits) and so-called modifiers, which can reduce the number of scored points from the dummy values, due to observations made in the high-speed films, dummy traces or based on structural problems in the vehicle such as deformation or potential risks for the passengers. This kind of assessment, which is also used in other full-scale tests, was also followed for the new MPDB test. With the assessment of the barrier/trolley performance for compatibility, a new modifier was introduced for the overall frontal performance of the tested vehicle.

### Approach

Euro NCAP's assessment of driver and passenger occupant protection will be based on dummy values, derived from lower and higher performance limits against a set of dummy criteria, and restraint and structural modifiers, such as airbag failure, pedal intrusion etc. Contrary to Hybrid-III, there are few industry accepted injury limits for THOR available and there is still a lack of information of injury risk curves or dummy limits published in the scientific community. The group analysed data from the round robin tests, ongoing research, publications and studied comparable tests between the Hybrid-III 50M and the THOR 50M to find correlations and set the first criteria and limits for the THOR 50M dummy.

### THOR Assessment Criteria

The initial list of criteria included more or less all parameters which have been considered by NHTSA, with the exception of those related to the THOR-LX as Euro NCAP has decided to use the Hybrid III 50% lower legs in the first step. These criteria are:

- HIC15
- BrIC/SUFHEM (monitoring)
- Neck forces and torque
- Chest displacement / Rmax
- Abd compression
- Left acetabulum load
- Right acetabulum load
- Left femur force
- Right femur force
- Left knee shear displacement
- Right knee shear displacement
- Left tibia index
- Right tibia index
- Left tibia compression
- Right tibia compression
- Pedal rearwards displacement

**Lower Leg, Knee and Femur** At the time that the group defined the THOR 50M specification in 2016, the decision was taken not to adopt the LX-legs, due to the status of the development of the legs, the high costs of obtaining and certification of the legs, and the relative low priority of lower leg injuries in the field. So, the Hybrid-III 50M lower legs were applied to the THOR femurs, including the knee slider of the Hybrid dummy. With the use of the Hybrid III parts, also the current Hybrid III 50M dummy criteria and upper and lower performance limits could be used for assessment. This includes the Tibia Index, the Tibia Force  $F_z$  and the knee slider performance. Euro NCAP also continues to monitor pedal rearward displacement and foot well

behaviour as part of the modifier assessment, a practical measure that has been an effective way to minimise the risk at foot and lower leg injuries in practice.

The other parts of the THOR assessment in the lower extremity area are the femur and the acetabulum. The Femur load is also based also on the Hybrid III 50M value and is evaluated in used in the compression phase. A preliminary NHTSA publication showed comparable values for H-III and THOR so the higher performance limit was set to 3,8kN and the lower performance limit to 9,07kN. The acetabulum calculation takes the resultant force of  $F_x$ ,  $F_y$  and  $F_z$  into account. Often the tension force  $F_x$  produces higher values than the compression force, but tests have shown that the compression force is the driving factor of injuries in the acetabulum region. Due to this fact, high resultant values of the acetabulum might not be problematic for the passenger as this will be result of the tension force primarily. To solve this issue, the Euro NCAP acetabulum calculation foresees that the resultant force is only calculated in the phase when  $F_x$  shows compression. The proposed limits were set to 3.28 as lower performance and 4.1 as higher performance limit.

**Chest and Abdomen** Actual crashes analysed by the group showed that chest and abdominal injuries are still the most common injuries in frontal impacts on European roads. This was the main motive to introduce THOR in the new frontal test. This dummy was designed to be more biofidelic in the chest and abdomen area than the Hybrid III dummy. The interaction with the restraint systems is expected to be more humanlike, due to its higher spine flexibility and improved anthropometry. Despite these advantages, however, the idea of using an advanced chest injury risk criterion of based on a combination of chest compression and geometric deformation, such as the PCA-score, turned out to be premature, as there is still work ongoing and only limited data are available to support biomechanical limits. In the introduction phase, the maximum deflection  $R_{max}$  will be the assessed criterion in the chest region. All ribs will be evaluated, while the rib with the highest compression is driving the assessment. The results of the SENIORS project [7] and the internal test runs of MPDB test from Euro NCAP were used to set acceptable upper and lower performance limits. It was also understood that the current vehicles tested were not optimized for the new dummy and future performance in cars will likely show better results. Based on these studies, the lower performance limit was set to 35mm, while the higher performance limit of 60mm is used.

Unfortunately, even less information is currently available regarding abdominal injury risk. Due to this fact, and primarily based on the experience in the full-size crashes, only the upper performance limit was defined, which will allow to Euro NCAP to identify vehicles showing elevated submarining risk. In addition, ASIS load cells will help to detect issues in performance of the lap belt section.

**Head and Neck** The current Euro NCAP assessment of the head includes the  $HIC_{15}$  and the 3ms resultant acceleration, taken from the dummy measurement. Both criteria will be also used with the THOR dummy as there is no influence of the dummy construction which might influence these criteria. These criteria however are not adequate to accurately assess brain injury risk and therefore additional criteria are under discussion for AIS 2+ injuries in front impact crashes. As further research is needed on this topic, Euro NCAP delayed the introduction of a brain injury risk criterion to 2022. In the meanwhile, it will monitor several possible criteria such as BrIC, UBrIC and criteria which include simulation models i.e. SUFHEM.  $HIC_{15}$  lower (500) and upper (700) values will be applied as well as the resultant acceleration 3ms limits of 72g for the lower performance limit and 80g for the upper performance limit.

For the neck,  $N_{ij}$  was not adopted. Instead, neck forces and bending moments are used for assessment, as is the case for the Hybrid III 5F and 50M. Comparing MPDB tests with the THOR and Hybrid III dummies, it was found that the neck tension force  $F_z$  correlates well between these two dummies and could be transferred to the THOR assessment, with a lower performance limit of 2.7kN and an upper performance limit of 3.3kN. This correlation could also be seen in certification tests, while shear force  $F_x$  and extension moment  $M_y$  did not show such correlation whether in certification or in vehicle crash tests. Euro NCAP continues to study the neck injury criteria and currently proposed limits remain to be confirmed at time of submitting this paper.

The situation with neck injury assessment is exacerbated by continuing neck certification issues as several production level THOR necks have not been passing the certification corridor that was previously agreed with the dummy manufacturer. This issue needs to be solved first, before final values for upper and lower performance of neck criteria can be defined.

In Table 1 all relevant criterion, with upper and lower limits are shown, as well as the point's calculation. The assessment is based on the worse scoring parameter of each individual body region and the overall score on the

worst scoring body region of the driver and the passenger. The passenger scoring remains unchanged from the ODB assessment in 2019.

**Table 1**  
**Injury criteria for THOR 50M ATD**

Body Region	Criterion	Unit	Upper	Lower	Scoring*
Head	HIC15		700	500	4 points
	SUFEHM				
	BrIC				
	A Resultant 3ms	g	80	72	
Neck	Fx	kN	3.1	1.9	4 points
	Fz	kN	3.3	2.7	
	My	Nm	57	42	
Chest & Abdomen	Chest compression / Rmax	mm	60	35	4 points
	Abdominal Compression	mm	88		
Knee, femur, pelvis	L/R Acetabulum	kN	4.1	3.28	4 points
	L/R Femur compression	kN	9.07	3.8	
	L/R Knee shear displacement	mm	15	6	
Lower leg	L/R Tibia index		1.4	0.4	4 points
	L/R Tibia Compression	kN	8	2	

*\*Based on worst-case parameter*

### Dummy Certification

With the introduction of the Service Built Level (SBL) B of the THOR 50M, also a certification procedure needed to be established. The lower leg and knee certification is based on the Hybrid III certification but from the femur to the head, a new set of certification procedures and limits were proposed, based on the THOR 50M, Qualification Procedure Manual 2016. This procedure is defined in the TB26 [8] of Euro NCAP.

### COMPATIBILITY ASSESSMENT

#### Rationale

Former research on compatibility has identified mass differential, stiffness of front structures and geometric alignment as the parameters most influencing vehicle incompatibility. The impact scenario of the proposed MPDB with 180° impact angle, will lead to a nearly vertical loading of the barrier, which enables a good calculation of the energy transfer into the barrier and measurement of the footprint in the barrier. ADAC previously used this scan in their assessment to rate the geometry and the stiffness of the tested vehicle [9], see Figure 2. The idea behind this assessment is to rate the homogeneity of the front structure. The flatter the surface, the better the load spread.

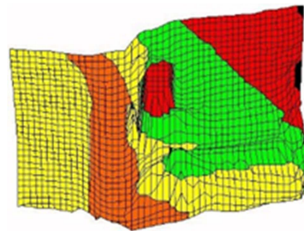

	weighting	rating
geometry/ homogeneity	75%	-
stiffness/ energy absorption	25%	⊖
compatibility		-

**Figure 2. PDB barrier scan and compatibility assessment by ADAC**

To investigate both the longitudinal and the area outside of the longitudinal, an assessment area is defined on the barrier front which depends on the vehicle width. The standard deviation of the intrusion in this assessment area is calculated, see Figure 3. The intrusion measurement is done by scanning the barrier footprint after the test. This is the first part of the assessment, reflecting geometry/ homogeneity.

The second part of the assessment is the deceleration of the mobile barrier and the energy absorption of the deformable element in the assessment area. The idea behind is to decelerate the trolley as slowly as possible, to avoid unnecessary loading of the partner car. Also, the less energy the test vehicle puts in the barrier the less energy the partner car needs to absorb. If stiff front-end vehicle parts bottom out the barrier, there will be an additional downgrading modification of the assessment. For this, a maximum intrusion of 633mm is proposed. The penetration of 633mm results in the maximum deformation of the first and the second honeycomb element and the block length of the honeycomb material and no deformation of the last element.

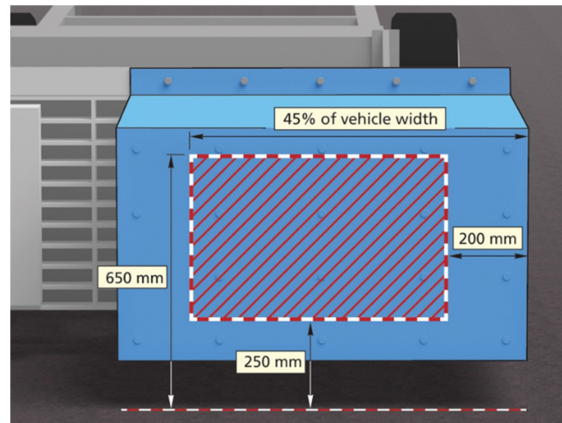

*Figure 3. Compatibility assessment zone*

The points distribution and the potential impact of the compatibility modifier on the rating was chosen to maximise the incentive for vehicle manufacturers to improve their structures, given what is feasible in a relatively short period. A good interaction between the different front structures is essential to activate the crash zones and to reduce the impact energy. Examples of a good geometric design, which helps to distribute the loads in several levels and also outside the longitudinal, are already available on the market and are easier to adopt than totally new crash energy management systems, which will take longer to implement and must be designed early in the construction process. Hence a weighting of the various rating elements was chosen that would incentive compatibility improvements in the fleet in a faster way.

The main elements used in the assessment were barrier scanning and calculation of the footprint and standard deviation, and the energy management of the barrier and trolley deceleration. As there was no clear proof from the accident data which of these two criteria should be prioritised, both are rated equally. Some of the vehicles tested, however, had very stiff longitudinal frames, which was seen to be critical in car to car impacts. Their localised “punch” effect could be reproduced in the MPDB test, however as this results in a relatively small area of penetration, this issue is not necessarily adequately reflected by the standard deviation. Therefore, it was decided to have this separately assessed and penalised in the score. Finally, the Occupant Load Criterion [10] was considered as the best way to evaluate energy management by assessing the vehicle stiffness indirectly with the barrier deceleration pulse.

In summary, the three agreed parameters for assessing the compatibility were:

- Standard deviation (SD) of the post-test barrier measurement,
- Occupant load criterion (OLC), according the deceleration pulse of the barrier,
- Bottoming out, measured by intrusion depth of the honeycomb.

### **Standard Deviation (SD)**

The homogeneity measurement is based on standard deviation (SD) of the measurement of the intrusion depth in the assessment zone (Figure 4). The assessment zone was taken over from the original ADAC rating as there was a lot of experience of testing vehicles against progressive deformable barriers faces. Due to the movement of the vehicle after the impact, the outboard side of the barrier will be loaded sideways, and the honeycomb faces are bent instead of compressed. This will result in a different deformation, so a distance of 200mm is excluded from the outboard side to the assessment zone. Due to issues in the upper and lower area,

resulting from behaviour of the cladding sheet, the lower rating area was set to 250mm from ground, while the upper area was set to 650mm from the ground. The width is based on 45% of the vehicle width.

The standard deviation is defined as the spread around the mean intrusion that covers 68.2% of all measured intrusion points. The bigger the standard deviation the bigger the spread of the intrusion points and the less the homogeneity of the structure. Steps in the deformation zone, such as single cross members, no structure in front of the road wheel etc. could be detected. The assessment of the SD is based on a linear scale from 50mm, higher performance limit, to 150mm, which is the lower performance limit.

**Reproducibility of the scanning method** to ensure that the scanning process and the used tools produced repeatable and reproducible SD results, the labs were trained how to deal with different deformed elements, ruptured barrier etc. Solutions were worked out to treat problems during scanning such as reflexions, open hexagons, etc. After that, one barrier was sent out to 5 different Euro NCAP accredited laboratories to perform a scan round-robin test. The barrier of the round robin was scanned in the individual labs, with different equipment and test crew. The results are shown in Table 2 as well as the different scans in Figure 4.

**Table 2**  
**SD of barrier scans measured at different labs**

Laboratory	Standard Deviation Measured (mm)
Lab1	42
Lab 2	42
Lab 3	41
Lab 4	42
Lab 5	41

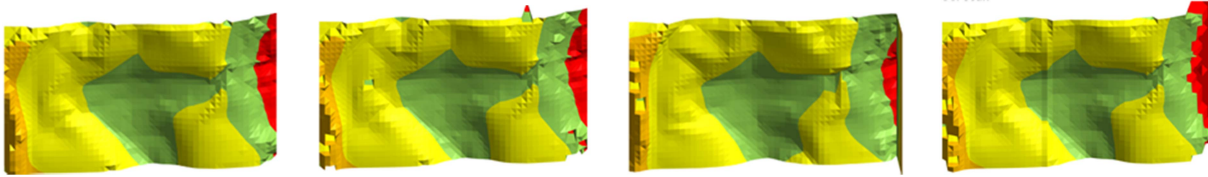

*Figure 4: Barrier scans round robin results for 4 out of 5 laboratories*

**Occupant Load Criterion (OLC)**

The occupant load criterium is based on the measured deceleration in the CoG of the trolley during the impact. After filtering the deceleration signal with CFC 180, the pulse should be integrated with the following equation to derive the velocity course of the barrier.

$$V_t = \int A_x(t) dt + V_0$$

Where  $V_0$  is the initial velocity of the barrier at  $t = 0s$ .  $OLC_{SI-unit}$ ,  $t_1$  and  $t_2$  can be calculated by the following equation system:

$$\begin{cases} \int_{t=0}^{t=t_1} V_0 dt - \int_{t=0}^{t=t_1} V(t) dt = 0.065 \\ \int_{t=t_1}^{t=t_2} (V_0 - OLC_{SI-unit} \times (t - t_1)) dt - \int_{t=t_1}^{t=t_2} V(t) dt = 0.235 \\ V_0 - OLC_{SI-unit} \times (t_2 - t_1) = V(t_2) \end{cases}$$

Where  $t_1$  is the end of the free flight phase of a virtual dummy on the trolley along a displacement of 0.065m and  $t_2$  is the end of the restraining phase of a “virtual occupant” on the trolley along a displacement of 0.235m after the free flight phase, resulting in a total displacement of 0.300m for the virtual occupant (Figure 5). For the compatibility assessment the OLC is converted into SI units ( $1g = 9,81m/s^2$ ). The OLC is evaluated using a sliding scale from 25g higher performance limit to 40g lower performance limit.

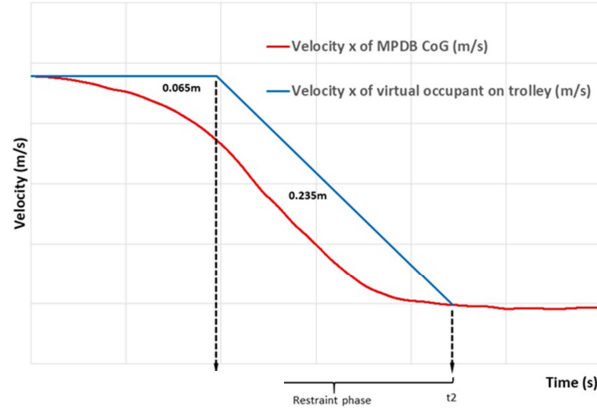

Figure 5. OLC and trolley velocity

### Bottoming Out

Bottoming out defines an area where a structure of the vehicle penetrated the barrier more than 630mm in depth and a width of more than 40mmx40mm.

### Compatibility Modifier

In the Euro NCAP rating scheme, maximum 16 points can be gained in the MPDB test, if all dummy criteria stay below the higher performance limits and no modifiers are applied. The contribution to the Adult Occupant Protection is half of that score, so a maximum 8 points, similar to the 8 points contribution of the Full-width frontal test.

The result of the compatibility assessment will be applied as a modifier to the total score of the MPDB test. The maximum modifier will be 8 points and will reduce the number of scored points of the occupant rating. In the first phase from 2020 to 2022, the result of the modifier will be limited to maximum of 4 points however to allow industry to adjust their vehicles step-wise. Both, the standard deviation (SD) and the OLC are assessed with a sliding scale with the upper and lower limits mentioned above. The bottoming out modifier is then added to the result. The general scoring rational is shown in Figure 6.

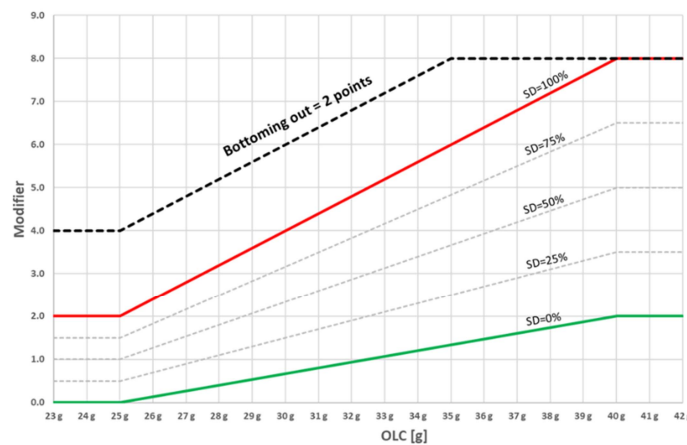

Figure 6. General scoring rational [8]



## VERIFICATION TESTS

A final check of the assessment procedure was carried during a final round robin full-scale test series. As part of this series, two pairs of vehicles were tested in different labs to check the test variation in setup, dummy results and compatibility assessment. The vehicles tested twice were the 2017 5-stars rated Honda Civic and the 2017 5-stars rated Ford Fiesta. Other vehicles were chosen to represent, different types of vehicles. Large SUV, smaller SUV, Supermini's as compact class cars were included. All cars were tested to assess the dummy values and the compatibility modifier. The following table is showing all tested vehicles during the 2nd round robin tests carried out in 2018.

**Table 3**  
**Full-scale validation MPDB test series: cars models, labs and barrier suppliers**

Model	Description	Lab	Barrier face
Honda Civic	5-star compact class (expected to show good compatibility assessment)	ADAC	Cellbond
		IDIADA	Cellbond
Ford Fiesta	5-star car used for validation tests (expected to show moderate compatibility)	BASt	AFL
		TASS	AFL
Jeep Renegade	Compact 5-star SUV	CSI	Cellbond
Jag E-Pace	Compact 5-star SUV vehicle (expected moderate compatible structure)	TASS (Thatcham)	AFL
Renault Clio	Supermini 5-star (expected to show good compatibility)	UTAC	AFL
Audi Q5	Large 5-star off-road vehicle, representing SUVs (expected not to have a compatible structure)	ACTS/CLEPA	Cellbond

### Dummy Results

In the initial phase of the working group's research, several R&R tests were carried out including sled tests, vehicle tests and certification tests to verify the reproducibility and durability of the latest THOR 50M and to identify what updates to the dummy would still be needed. Since then, several improvements were adopted, related to the dummy hardware, handling and certification. The largest step forward was the definition of a Service Built Level of the dummy, because up until that time many of the THOR dummies in the field were of a different built status, causing much confusion and frustration amongst the user community. During the round robin validation tests, all THOR 50M dummies were brought up to SBL-A (later followed by B) to avoid unnecessary discussions and wasting valuable resources.

In the first set of cars, two 2017 Honda Civic were used, a five-star Euro NCAP car with an ODB assessment score of 7.1 pts. This car was tested in 2 different labs, with 2 different THOR dummies on the driver seat. The overall results showed that there was no significant change in performance in the head/neck and knee/femur/pelvis area between the two lab results. The lower legs, which showed in the ODB test good results scored 0, respectively 0,09 points, in the MPDB tests, due to the values of the lower Tibia Index, which was unexpected. On the other hand, the chest deflection, Rmax showed a chest injury risk that was significantly higher than in the original ODB with the Hybrid III, as anticipated. The deflection values between the two MPDB tests were significant different owing to different belt behaviour as could be observed in high speed video. All other values showed equivalent results, as shown in Table 4.

**Table 4**  
**Full-scale validation MPDB test results: Paired comparisons**

	Honda Civic (2017)		Ford Fiesta (2017)	
	IDIADA	ADAC	BAST	TASS
Head & Neck	4.00	4.00	4.00	4.00
Chest & Abdomen	0.80	2.02	0.26	0.11
Knee, femur, pelvis	4.00	4.00	4.00	4.00
Lower Leg	0.00	0.09	2.67	2.15
Total	8.80	10.11	10.93	10.27



The second set of cars that were tested under the same condition but in different labs, was the 2017 Ford Fiesta.

In the 64kph ODB test with the Hybrid III dummy on the driver seat, the overall performance was excellent, scoring 7.7 points out of 8 points. In the MPDB test, the Ford Fiesta scored less points in the chest and the lower leg area. The results of both test labs matched quite well.

A similar conclusion could be drawn from the remaining vehicles tested in this series. As expected from the THOR 50M the chest area is the predominant cause for points reduction, followed by the lower leg area. Even the larger cars such as the Jaguar E-pace and the Audi Q5 demonstrated weaker performance in the chest area, sometimes exceeding the lower performance limit significantly. Higher Tibia Index values were the main cause for lower scores in the lower legs. All results of the round robin 2 could be seen in Table 5.

**Table 5**  
**Full-scale validation MPDB test results: All cars**

	Honda Civic	Honda Civic	Ford Fiesta	Ford Fiesta	Jeep Renegade	Renault Clio	Jaguar E-Pace	Audi Q5
	IDIADA	ADAC	BASt	TASS	CSI	UTAC	TASS	ACTS
Head & Neck	4.00	4.00	4.00	4.00	4.00	4.00	4.00	4.00
Chest & Abdomen	0.80	2.02	0.26	0.11	2.58	0.00	2.71	0.00
Knee, femur, pelvis	4.00	4.00	4.00	4.00	4.00	2.01	4.00	4.00
Lower Leg	0.00	0.09	2.67	2.15	3.64	0.93	3.49	2.67
Total	8.80	10.11	10.93	10.27	14.23	6.94	14.20	10.67

### Compatibility Assessment

All vehicles in the previous and final validation test series were rated according the agreed version of the compatibility assessment. Figure 7 shows the modifier on the LHS according the OLC on the x-axis. The red line shows the SD of 100% and the green line at 0%. The overall results show a wide spread of results, but also the differences between vehicle classes.

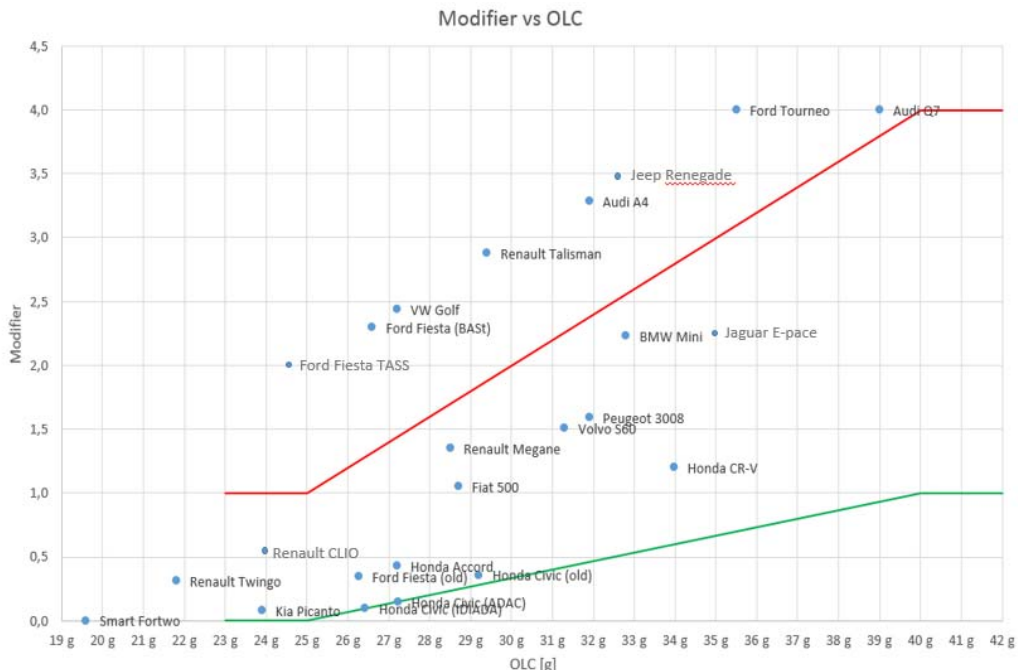

**Figure 7. Compatibility Rating for cars tested in first and second validation test series**

Small SUV`s such as the Jeep Renegade, the Jaguar I-Pace and the Honda CR-V, show a significantly drop in modifier scoring, even their OLC is more or less the same. On the other hand, vehicles of the same mass show a reduction in OLC, which means with a different front structure the accident partner could be loaded less. Examples are the Audi A4, the Renault Megane and the Honda Accord, while the Audi showed the highest OLC.

Both test pairs of Fiesta and Civic show a good reproducibility of the compatibility assessment. In different test labs, and with cars not being designed for this load case, the overall compatibility result shows only minor differences. In the case of the Fiesta it is 0.1 points difference, while in the Civic test it is only 0.05 points difference. Even as the footprints in the Ford Fiesta test were not exactly identical, due to a slightly different behaviour of the front cross member, the overall compatibility assessment itself is not really affected, which demonstrates that the method of the assessment itself is robust. In case of the Honda Civic, both footprints also showed nearly identical measures (Figure 8). Bearing in mind the small variations that can occur in the scanning process, the overall compatibility assessment shows to be repeatable and robust.

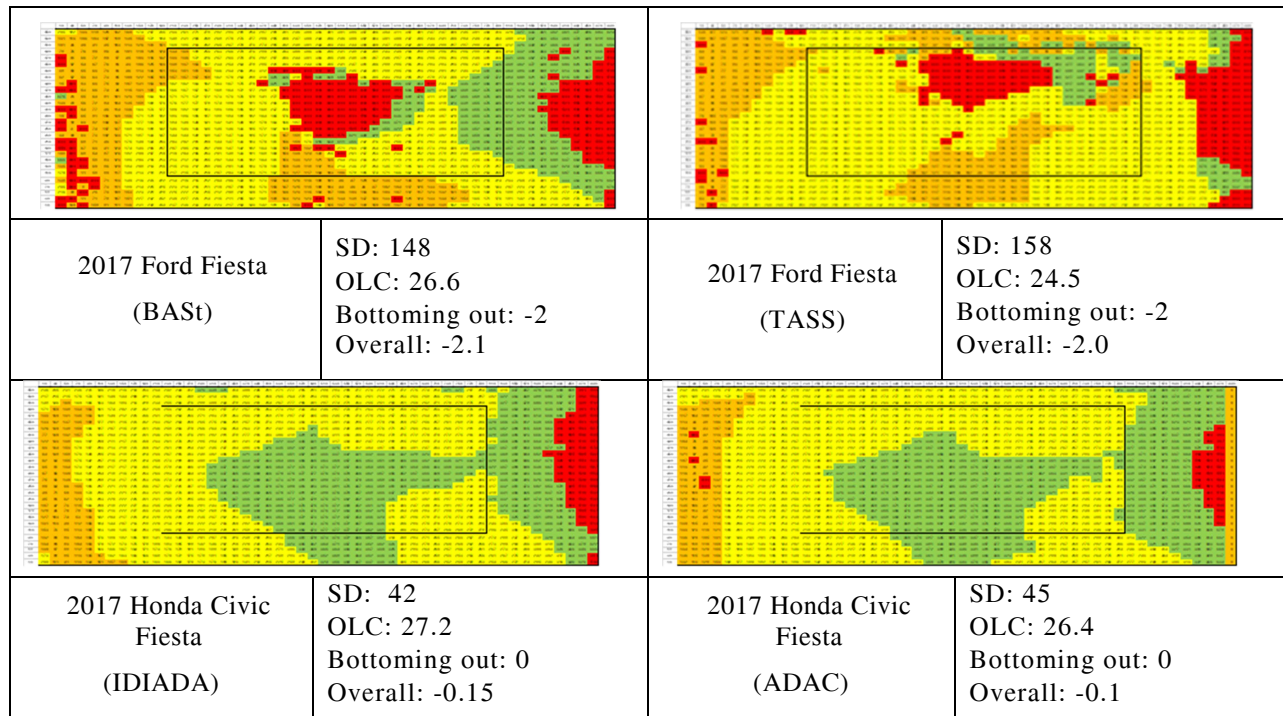

*Figure 8. Comparison of barrier scans from full-scale tests*

## CONCLUSIONS

In the second and final phase of the development of a new frontal impact test with a mobile barrier, the work has focussed on dummy criteria, dummy certification and the new compatibility assessment. As there was only limited information available on the THOR-dummy injury risk curves, sled and full-scale crashes were carried out to find appropriate upper and lower limits of the different body regions that could be applied from 2020 onwards. Some practical considerations were used to decide on the limits. The repeatability and reproducibility of the dummy in certification tests was also studied and certification corridors for THOR 50M use for Euro NCAP testing were agreed.

The definition of a built level allowed the group to carry out round robin tests to validate the procedure, criteria and also to confirm the reproducibility of the test. The results showed that under the new configuration of this frontal test, the THOR was usable and durable. The chest and lower leg will be the more demanding body regions for the future assessment, as nearly all the cars showed lesser performance in this area compared to the ODB results. It appears that the chest result was influenced by the THOR chest behaviour, the restraint

systems not being developed to accommodate for the more flexible rib cage. The lower leg result seems to be caused by the new test condition, as there was no change in the legs themselves (i.e. Hybrid III legs).

After decades of discussions on compatibility and possible ways to assessment it, a way was agreed in the Euro NCAP frontal impact group to rate the compatibility of test vehicles. Internal test series have shown that the barrier and deceleration assessments correlate with car to car crashes. R&R work in the group, carried out together with suppliers and vehicle manufactures, show a stable test procedure with repeatable and reproducible results. Even the assessment criteria may need further consideration in future, the first step was undertaken to use this test device in a consumer test program.

More work will be undertaken by Euro NCAP in the way to assess brain injuries and improve chest assessment taking the whole chest loading into account. Even without these advanced criteria, however, it is expected that the introduction of the new test will still promote the development of better restraint systems.

## **ACNOWLEDGEMENTS**

Members of the FIWG are:

Sandner Volker, ADAC (WG Chairman)  
Ellway James, Euro NCAP (Secretary)  
Michiel van Ratingen, Euro NCAP  
Tobias Langner, BASt,  
Ammerlaan Hans, NL-MOT-RDW  
Baroncelli Luca, CSI  
Broscheidt Michael, Audi  
Herpich Thomas, TRW  
Langner Tobias, BASt  
Lázaro Ignacio, IDIADA  
Lepretre Jean-Philippe, UTAC CERAM  
Thorsten Kerz, Opel  
Ratzek Andreas, ADAC  
Thompson Alex, Thatcham  
van Montfort Sjef, TNO  
van Slagmaat Marc, Autoliv  
Jeremy Magniez , UTAC CERAM  
Weimer Christoph, Hyundai

The working group would also like to that the support of David Hynd, Chairman of the TEFIRE group, the barrier manufacturers who have contributed to the development of the MPDB specification: Cellbond, AFL and Plascore, and the dummy manufacturers Humanetics Innovative Solutions and Cellbond ATD.

## **REFERENCES**

- [1] Johanssen H et al. 2012 “Documentation for a frontal impact and compatibility assessment approach: Part II”.
- [2] VC Compat report, 2006. “Improvement of Vehicle Crash Compatibility through the development of Crash Test Procedures”.
- [3] Saunders et al, 2012. “Moving Deformable Barrier Test Procedure for Evaluating Small Overlap/Oblique Crashes.” SAE paper number 2012-01-0577.
- [4] Sandner V. 2017. “Euro NCAP Frontal Impact Working Group Report.” In Proceedings of the 25<sup>th</sup> ESV Conference, paper number 17-0206.
- [5] Sandner et al, 2015. “MPDB-Mobile offset progressive deformable barrier.” In Proceedings of the 24<sup>th</sup> ESV Conference, paper number 15-0389.

[6] Euro NCAP. 2016. "Mobile Progressive Deformable Barrier Face Specification" Technical Bulletin TB022.

[7] European Commission 2018. "SENIORS project report" [www.seniors-project.eu/](http://www.seniors-project.eu/)

[8] Euro NCAP. 2018. "*THOR Specification and Certification*" Technical Bulletin TB026, v1.0.

[9] ADAC 2016 Compatibilty Crash, Test report, Andreas Ratzek 2016

[10] J. Metzger, L. Kübler, S. Gargallo. 2010. "Characterization and Evaluation of Frontal Crash Pulses for USNCAP" In Proceedings of the 10th International Symposium and Exhibition on Sophisticated Car Occupant Safety Systems", Airbag 2010 Conference.